

DELTA AC-evo / DELTA E AC-evo / DELTA UB AC-evo

Strong and Reliable

 Capacity (kg): 1200 - 1500  Lifting Height (mm): 1600, 2500, 3000, 3500

DELTA AC-evo

A rugged and reliable stacker for continuous duty pallet handling requirements in medium and large work sites.

AC technology

- + Performance
- + Driving control
- Service Costs



DELTA E AC-evo

Version equipped with extruded-metal mast and special steel sections for heavy-duty operations.



Lateral safety boards for the maximum safety of the operator (Optional)

DELTA UB AC-evo

To increase efficiency and reduce operator fatigue in large work sites, the driver-on-board option allows operator stands on a platform while the truck is in motion.

FULLY POWERED STACKERS

Features in detail:



NEW "DR EVO" DRIVE STEERING:

Includes LED battery charge indicator, "turtle" switch for variable speed control, precision proportional lifting / lowering control and safety reversing (crushproof) switch.



FREEDOM FROM DOWNTIME:

Powered by 24V industrial batteries with capacities to 270 Ah. A battery charger is built-in to the stacker control housing and includes a 220VAC power cord.



TRACTION AND STABILITY:

Structure with 5 contact points and shock-absorber system for perfect grip by the driving wheel in case of floor irregularities. AC traction drives offer maximum responsiveness in starting and during braking.



MAINTENANCE:

High frequency 24V microprocessor controls with LED function indicators allow fast and easy troubleshooting. Includes PC control software.



DELTA AC-evo

model	125/16	155/16	125/25	155/25	125/30	155/30	125/35	155/35
Q Kg	1200	1500	1200	1500	1200	1500	1200	1500
C mm	600	600	600	600	600	600	600	600
I mm	1150	1150	1150	1150	1150	1150	1150	1150
L mm	1895	1915	1930	1950	1930	1950	1930	1950
X mm	380	380	415	415	415	415	415	415
X2 mm	175	175	175	175	175	175	175	175
Y mm	1340	1360	1340	1360	1340	1360	1340	1360
L2 mm	745	765	780	800	780	800	780	800
M mm	530	530	530	530	530	530	530	530
N mm	160	160	160	160	160	160	160	160
h1 mm	1990	1990	1740	1740	1990	1990	2240	2240
h2 mm	1450	1450	200	200	200	200	/	/
h3 mm	1600	1600	2500	2500	3000	3000	3500	3500
h4 mm	2120	2120	3020	3020	3520	3520	4020	4020
B mm	840	840	840	840	840	840	1000*	1000*
WA mm	1500	1520	1530	1550	1530	1550	1530	1550

STANDARD EQUIPMENT

- AC three-phase technology traction motors • Electronic plant 24V with controller with mosfet technology complete with inverter and microprocessor fault research • Regenerative braking with consumption reduction and temperature control of the traction motor
- Free lift 200 mm (excluded lifting height mm. 3500) • Built-in electronic battery charger 24V 30A with microprocessor • Forks control by push-buttons • Fixed forks length mm. 1150 • Electric end stroke • Parking Brake • Shock absorber on driving-wheel
- Side wheels with extra-heavy castors • Exhausted battery warning-indicator • DR-EVO Steering • Automatic speed reduction
- Safety components • Traction Battery 24V from 160 to 270 Ah

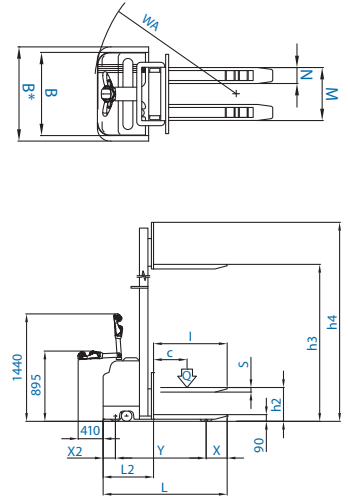

DELTA E AC-evo

model	125/16	155/16	125/25	155/25	125/30	155/30	125/35	155/35
Q Kg	1200	1500	1200	1500	1200	1500	1200	1500
C mm	600	600	600	600	600	600	600	600
I mm	1150	1150	1150	1150	1150	1150	1150	1150
L mm	1880	1880	1915	1915	1915	1915	1915	1915
X mm	375	375	410	410	410	410	410	410
X2 mm	175	175	175	175	175	175	175	175
Y mm	1330	1330	1330	1330	1330	1330	1330	1330
L2 mm	730	730	765	785	765	785	765	785
M mm	530	530	530	530	530	530	530	530
N mm	160	160	160	160	160	160	160	160
h1 mm	1990	1990	1740	1740	1990	1990	2250	2250
h2 mm	1450	1450	200	200	200	200	/	/
h3 mm	1600	1600	2500	2500	3000	3000	3500	3500
h4 mm	2120	2120	3020	3020	3520	3520	4020	4020
B mm	840	840	840	840	840	840	1000*	1000*
WA mm	1500	1520	1530	1550	1530	1550	1530	1550

STANDARD EQUIPMENT

- AC three-phase technology traction motors • Electronic plant 24V with controller with mosfet technology complete with inverter and microprocessor fault research • Regenerative braking with consumption reduction and temperature control of the traction motor
- Free lift 200 mm (excluded lifting height mm. 3500) • Extruded mast with lateral contrast bearings • Built-in electronic battery charger 24V 30A with microprocessor • Forks control by push-buttons • Fixed forks length mm. 1150 • Electric end stroke • Parking Brake • Shock absorber on driving-wheel • Side wheels with extra-heavy castors • Exhausted battery warning-indicator • DR-EVO Steering • Automatic speed reduction • Safety components • Traction Battery 24V from 160 to 270 Ah

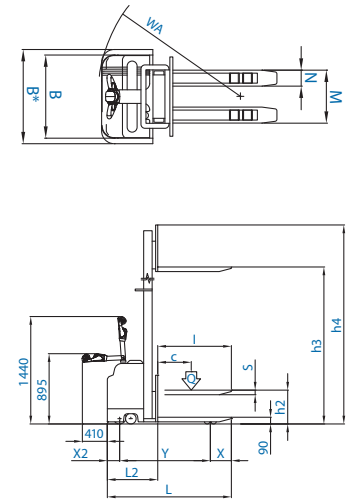

DELTA UB AC-evo

model	125/16	155/16	125/25	155/25	125/30	155/30	125/35	155/35
Q Kg	1200	1500	1200	1500	1200	1500	1200	1500
C mm	600	600	600	600	600	600	600	600
I mm	1150	1150	1150	1150	1150	1150	1150	1150
L mm	2000	2020	2035	2055	2035	2055	2035	2055
X mm	380	380	415	415	415	415	415	415
X2 mm	280	280	280	280	280	280	280	280
Y mm	1340	1360	1340	1360	1340	1340	1340	1360
L2 mm	850	870	885	905	885	905	885	905
M mm	530	530	530	530	530	530	530	530
N mm	160	160	160	160	160	160	160	160
h1 mm	1990	1990	1740	1740	1990	1990	2240	2240
h2 mm	1450	1450	200	200	200	200	/	/
h3 mm	1600	1600	2500	2500	3000	3000	3500	3500
h4 mm	2120	2120	3020	3020	3520	3520	4020	4020
B mm	840	840	840	840	840	840	1000*	1000*
WA* mm	2020	2040	2050	2070	2050	2070	2050	2070

STANDARD EQUIPMENT

- AC three-phase technology traction motors • Electronic plant 24V with controller with mosfet technology complete with inverter and microprocessor fault research • Regenerative braking with consumption reduction and temperature control of the traction motor
- Free lift 200 mm (excluded lifting height mm. 3500) • Built-in electronic battery charger 24V 30A with microprocessor • Forks control by push-buttons • Fixed forks length mm. 1150 • Electric end stroke • Parking Brake • Shock absorber on driving-wheel • Side wheels with extra-heavy castors • Folding footboard for operator • Exhausted battery warning-indicator • DR-EVO Steering • Automatic speed reduction
- Safety components • Traction Battery 24V from 160 to 270 Ah

